

Adsorption Air-Conditioning for Containerships and Vehicles

FINAL REPORT

Craig Christy, Dave Fusco and Reza Toossi

California State University Long Beach

METRANS contract number 65A0047

June 27, 2001



Disclaimer

The contents of this report reflect the views of the authors, who are responsible for the facts and the accuracy of the information presented herein. This document is disseminated under the sponsorship of the Department of Transportation, University Transportation Centers Program, and California Department of Transportation in the interest of information exchange. The U.S. Government and California Department of Transportation assume no liability for the contents or use thereof. The contents do not necessarily reflect the official views or policies of the State of California or the Department of Transportation. This report does not constitute a standard, specification, or regulation.

Abstract

This project investigates the vapor compression air-conditioning (A/C) system that utilizes an adsorption compressor that replaces the conventional mechanical compressor. The potential application of an advanced design to the needs of the transportation sector is the focus for this work. Much of phase I effort was to refurbish the system to safe operating condition, and to evaluate its performance. The system coefficient of performance for both mechanical and adsorption type compressor operations were 1.99 and 0.68 respectively. Phase II experimental work will include a detailed characterization of the adsorption beds, optimization of the operating temperatures, and cycling algorithm. The results of this work will provide the basis for design of improved sorption refrigeration systems for automotive and space conditioning applications.

Table of Contents

DISCLAIMER	II
ABSTRACT	III
TABLE OF CONTENTS	IV
DISCLOSURE	V
PHASE I DELIVERABLES	1
INTRODUCTION	2
ADSORPTION COMPRESSION REFRIGERATION	4
PRINCIPLES OF ADSORPTION	6
GENERATIVE AND NON-GENERATIVE ADSORPTION	7
APPLICATIONS IN AUTOMOTIVE AIR CONDITIONING SYSTEMS	9
MECHANICAL COMPRESSION A/C SYSTEM	10
SYSTEM DESCRIPTION	14
INSTRUMENTATION	15
DATA ACQUISITION	16
RESULTS	17
<i>Coefficient of Performance</i>	18
ADSORPTION COMPRESSION A/C SYSTEM	19
COMPRESSOR ELEMENTS	20
CYCLING	23
RESULTS	28
<i>Coefficient of Performance (COP)</i>	31
OPERATIONAL CONCEPT OF ADSORPTION A/C FOR AUTOMOBILES	32
CONCLUSIONS AND RECOMMENDATIONS	35
REFERENCES	36

Disclosure

Project was funded in entirety under this contract to California Department of Transportation.

Acknowledgments

The authors thank the CSULB Engineering Department, Mechanical Technician Manager Mike Fritz and Engineering Facilities Manager Mike Berg, for their support. We also thank METRANS for their interest in this research effort and providing grant support that allowed this research to happen.

Phase I Deliverables

Task 1 – Installation – the electrical system, implementing several layer of safety was designed. Hydraulic lines were checked to assure safety, absence of leaks, and corrosion. Faulty lines were repaired. The sorption refrigeration system was r refurbished, tested and is now functional. Safety procedures were written.

Task 2 – Data Acquisition System – Data acquisition system was designed, sensors installed, and necessary software for accurate measurement of data, recording, and analysis of various state parameters were developed. LabView software was modified for appropriate interface, valve operation, and cycling. Data measured were refrigerant flow rate, temperature and pressure.

Task 3 – Testing and Analysis – This task involves collecting test data for various configurations, temperature sources and refrigerants. Based on these measurements, the cycle coefficient of performance was determined. Due to refurbishment difficulties, time did not allow comparisons to be made with conventional ammonia solution refrigeration (absorber/pump/regenerator) systems.

Task 4 – Estimate the Potential Improvement over Conventional A/C Systems – This task was addressed in the Applications section of this report. In summary, conventional systems add a load to an automobile engine when it is least desired such as on a hot day and the conventional system also consumes fuel and in turn produces added emissions. Adsorption compression does not load the engine, consume fuel nor increase emissions.

Task 5 – Reporting and Dissemination – Quarterly Progress reports and a comprehensive final report was prepared. The theory, operating manual, safety procedure, test results and analysis were documented and are available on-line. A tutorial including the principles of refrigeration and air conditioning, sorption and refrigeration is prepared and is available on-line (See <http://www.csulb.edu/~rtoossi/metrans>).

Introduction

Sorption refrigeration system has been widely used in advanced cryogenic coolers onboard surveillance satellites, but the use of this technology for non-military commercial applications are rather new. Because the sorption compressor is thermally driven, any number of acceptable fuels, electric heaters or waste heat can power it. This flexibility can help allow the technology to be adapted to a wide variety of mobile or transit applications. Some potential applications are A/C systems for transit vehicles, containership, or residential heating and cooling. The source of heat could be the waste heat from exhaust gasses or engine coolant, regenerative braking, solar energy or photovoltaic. Although the state of the art has not allowed the adsorption system to be commonly used for vehicle air conditioning, which has a relatively large refrigeration power requirement, absorption-cooled mini-refrigerators have been marketed for recreational vehicles (motor homes, boats, etc). The need exists for a creative design to allow the technology to be practical for a transit vehicle's A/C.

The common automobile air conditioner uses shaft work of the engine to turn a mechanical compressor. Operating the mechanical compressor increases the load on the engine and therefore increases fuel consumption, emissions and engine operating temperature. A sorption compression system can utilize the exhaust heat or the heat absorbed by the cooling water. This heat, which could be considered as free energy, would be enough to drive a sorption refrigeration system. Presently there are road signs posted in hot areas with steep road grades stating to "Turn Off A/C on grade". The sign is meant to help reduce load on the standard cars engine in attempt to avoid overheating the engine. A diesel truck freightliner, which carries produce needing refrigeration, could employ the adsorption refrigeration system, run from the heat of exhaust or engine cooling water, to cool the cargo. The absorption system (typically ammonia-water) is currently used in motor homes for refrigeration, but it depends on the burning of natural gas to produce the heat required. An adsorption compression refrigeration system could do the same.

Typical automotive air conditioners utilize a mechanical compressor that typically has power consumption in the order of 2 to 5 horsepower. The mechanical compressor consumes a percentage of the total engine power depending on the vehicles transportation load such as freeway cruising, carrying large cargo weight, and climbing a grade. Depending on load, the compressor can consume up to 10% of the engines output.

A new vapor compression concept utilizing a sorbent material and waste heat is the subject of the current study. Unlike conventional vapor compression systems which require a mechanical compressor assembly, the new technology uses a thermally driven static sorption bed and thus can save as much as 90% of the required input power typically used to drive a mechanical compressor. The system takes advantage of the ability of certain materials, such as activated carbon or "charcoal" to sorb (soak up) a relatively large quantity of refrigerant vapor at some low temperature and pressure. The refrigerant is subsequently released at a higher pressure simply by applying heat. The activated material (sorbent material) is stored in a canister (sorbent bed). Multiple sorbent beds (minimum of 4) maintain a continuous flow of compressed refrigerant to the system by maintaining one bed always hot (and releasing refrigerated vapor) and one bed always cold (and sorbing refrigerant vapor). The other two beds are at intermediate

temperatures. One is being heated while the other is being cooled. A heat regeneration fluid can be used to increase system efficiency by means of transferring heat from a hot bed to a cold bed.

Since there are no moving parts (other than valves) the sorption system is considerably simpler, requires no lubrication and thus little maintenance. If the sorption system does not require and therefore utilize a heat regenerative fluid, the hardware associated with heat regeneration is eliminated and the system is even further simplified needing only refrigerant check valves. Other advantages include quiet operation and modularity so it is readily scalable for increased heating and cooling capacity by additional beds. Furthermore, most any heat source (such as waste heat or renewable energy) can be used and so energy saving can be potentially significant. Although the system can use conventional refrigerants such as R-134A, the sorption bed operates most efficiently when non-chlorofluorocarbon (CFC) based refrigerants, such as ammonia, are used.

The test bed (donated by MTA) required significant refurbishment. The activation of the test bed provided experimental data to provide direction and verification for the extensive analytical work required of this research effort. Phase I funding was used to install electrical and water systems, servicing and refurbishment of the system, and for carrying out the preliminary tests and analysis. Detailed analysis and additional test will be carried out in Phase II effort.

Specifically, METRANS Phase I funding supported the following tasks:

1. Prepared the system for safe operation that included fluid and electrical installations and preplanned checkout operations to assure system integrity.
2. Installed and developed sorption system valve control software and a data acquisition system
3. Initiated operation of the system and collected test data to analyze and baseline the system. The cycle coefficient of performance was determined and compared to conventional systems.
4. Preliminary designs and system concepts are suggested for ground vehicle transportation uses.
5. Evaluated system's potential for reducing pollution, reducing size, increasing efficiency and miniaturization required to allow the technology to become a commercially viable option for transit services.
6. Developed a website for use and others interested in sorption refrigeration technologies.

Examples of applications where sorption systems may offer superior performance and flexibility to conventional systems may include:

1. Air conditioning system for large trucks, buses, and ships —The waste heat from an engine can be used to heat the refrigerant to high pressures and temperature, thus removing the need for a mechanical compressor and reducing operating costs.
2. Refrigeration of containerships carrying perishable goods-- such as foodstuffs and certain chemicals. Furthermore, systems for containerships can be self-contained, self-cooled, environmentally benign, and with no or few moving parts. In hot and desert climates, where cooling is most desired, this system is particularly attractive because energy required for heating the refrigerant can be accomplished entirely by solar energy. The higher the intensity of solar heating, the more cooling can be made

available. Currently containers requiring refrigeration employ conventional Freon vapor compression units requiring electric power or fossil fuel. The absorption units are advantageous if for no reason other than the absence of reciprocating or rotating components to maintain.

Vapor Compression Refrigeration Systems

Background

Before discussing the sorption compression system, a few words about refrigeration in general are discussed. A simple and basic mechanical refrigeration system is introduced. There are four basic stages which make this mechanical refrigeration system work: Compression, condensation, throttling (expansion), and evaporation. See Figure 1.

Figure 1. Vapor-Compression Refrigeration Cycle

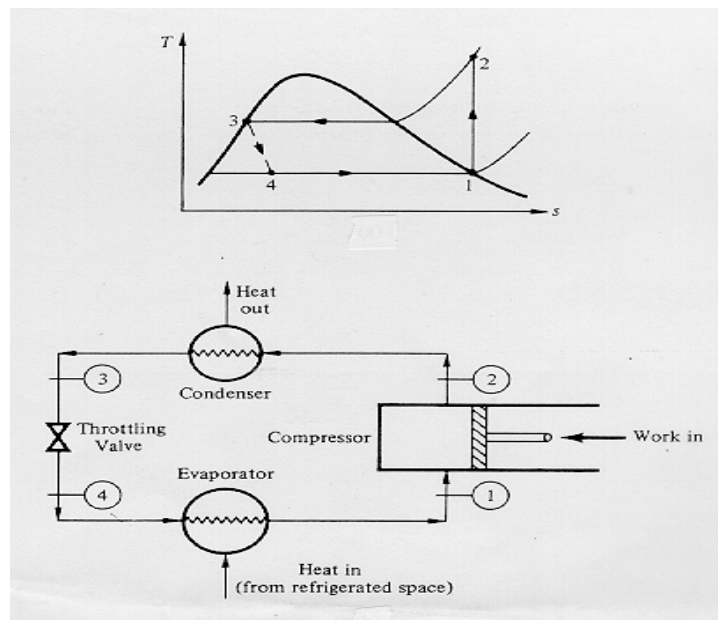

Vapor refrigerant is compressed in the compressor, where its temperature is raised above the temperature of the cooling medium used at the condenser. Vapor and liquid mixture refrigerant then enters the condenser where heat is extracted, and refrigerant changes to a liquid. It then enters the thermal expansion valve which controls the quantity of liquid refrigerant passing to the evaporator coils and is designed to maintain a constant degree of superheat of the gas leaving the coils regardless of suction pressure. Finally, the refrigerant enters the evaporator, absorbs heat and eventually returns to the compressor to start the whole cycle again.

An absorption refrigeration system is similar to the compression refrigeration system except heat instead of work provides the energy needed for compression. In this system compressor is replaced with a vapor generator, an absorber and a liquid pump. Refrigerant is absorbed in an

absorbent. The low-concentration solution is heated and compressed by a small liquid pump into the regenerator. When heat is added to the regenerator, refrigerant vapor is driven off into the condenser.

The adsorption compression system uses a thermally driven static sorption bed for the compression stage. A sorbent material such as activated carbon or “charcoal” is allowed to sorb or soak up the refrigerant at low temperature and low pressure. The sorbent material is then heated and the refrigerant is released at a higher pressure (i.e. compress refrigerant thermally versus mechanically). The sorption compressor is essentially a solid-state heat-activated substitute for the mechanical compressor.

To increase the efficiency and provide continuous cooling, more than one sorption bed are often used. The heat regeneration scheme used in our system with four beds, one bed is cool and soaking up refrigerant, a second bed is cooling down in preparation for sorbing, a third bed is hot and releasing refrigerant to provide a supply of high pressure refrigerant and the remaining bed is heating up in preparation for release. An electric heater is used to heat the refrigerant before it is released in the condenser. The electric heater used in this research, would be replaced with the waste heat source for a practical application.

The air conditioning system, either with or without adsorption compression, utilizes ammonia as the refrigerant because of its high refrigeration efficiency, low cost and low environmental impact. Besides the water circulation system used for the sorption compression regeneration, a separate water recirculation is also used to provide heat transfer from the cooled ammonia to the recirculation water. The cold water then extracts heat from air flowing through the air-handling unit. Thus, air conditioning is achieved. See Figure 2 for a block diagram of this air conditioning system with sorption compression. The hardware at CSULB was designed per all applicable ASHRAE standards for ammonia systems.

Figure 2. Schematic of Test Unit - Vapor Compression Air Conditioner with

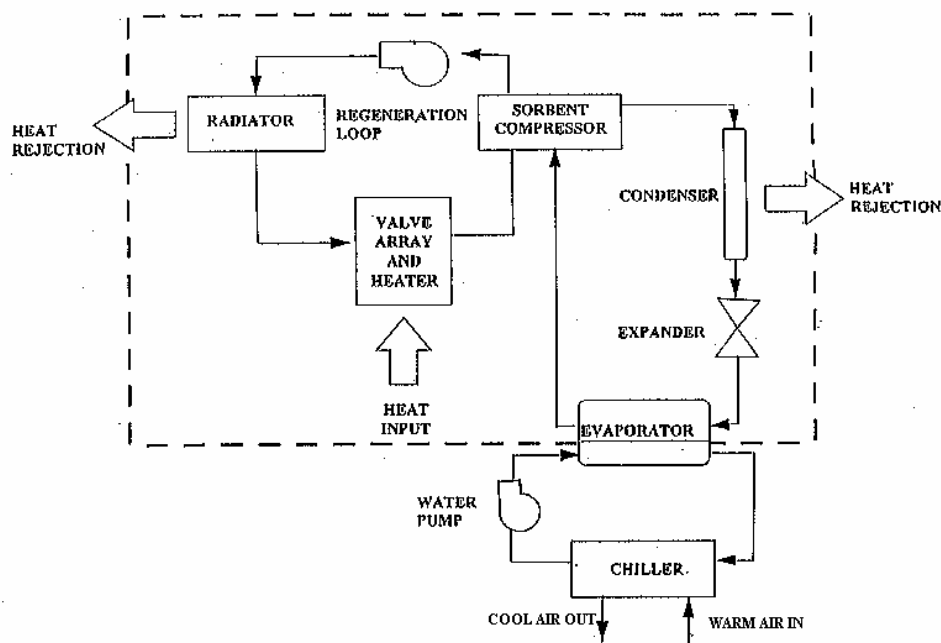

Principles of Adsorption

Sorption refers to the binding of one substance to another substance. A sorbent is a material that has the ability to attract and hold gases or liquids. The gas or liquid that is held by the sorbent is typically referred to as the sorbate. A desiccant is one common type of sorbent used primarily to attract and hold water sorbate. Most materials act as a sorbent to some degree, however there are some materials that have a much greater ability to attract and hold certain gases or liquids. This sorption process of attracting and holding another substance can be further classified as adsorption or absorption. Adsorption occurs when the sorbent does not change form during the sorption process. This is similar to a sponge that soaks up water; the sponge remains a solid during the process. Most adsorbent materials are solids. Absorption, on the other hand, changes the sorbent. Salt will absorb moisture and change from a solid to a liquid during the process. The sorption refrigeration principles addressed in this paper deal strictly with adsorption processes.

An important characteristic of solid adsorbent materials is the amount of internal surface area per unit mass. Activated carbon makes an excellent sorbent since it is extremely porous and thus provides a tremendous amount of internal surface area. A single gram of activated carbon can consist of up to 10,000 square inches of surface area. If a sample of carbon is exposed in a closed space to a gas such as ammonia, the carbon will begin to adsorb the ammonia. If the weight of the carbon and the pressure of the ammonia gas were measured, one would find that the carbon weight will increase and the gas pressure will decrease. After a fixed amount of time, the weight and pressure will become constant. The amount of ammonia gas adsorbed to the carbon could then be calculated using gas laws given the container and carbon volume. This entire process is also highly dependent upon several other variables including temperature, physical characteristics of the solid such as surface area and porosity, and physical characteristics of the gas such as molecule size. Thus, the quantity of gas adsorbed (n) by a solid is a function of temperature (T), pressure (p), solid characteristics, and gas characteristics.

$$n = f(p, T, \text{solid}, \text{gas})$$

For a given gas and solid combination at a set temperature, this expression can be simplified to:

$$n = f(p)_{T, \text{solid}, \text{gas}}$$

This expression defines the adsorption isotherm of a given solid / gas combination. Numerous adsorption isotherms for a wide variety of solid/gas combinations have been developed over the last century and are published in various references on this subject.

Performance of carbon adsorption refrigeration systems can be modeled by one of two common equations known as the Dubinin-Astakhov (D-A) and Dubinin-Radushkevitch (D-R) equations^{1,2}. These equations give an estimate of the amount of adsorbent that activated carbon can adsorb at a given temperature. The derivation of the D-A and D-R equations are out of the scope of this paper and is given in references 1 and 2, however, some working knowledge of these equations to develop an understanding of the adsorption characteristics is useful.

The D-R equation is given as:

$$W = W_0 \exp - \left[\left(\frac{k}{\beta^2} \right) (RT \ln(p_0/p))^2 \right]$$

The D-A equation is given as:

$$W = W_0 \exp - \left[\left(\frac{1}{\beta} \right)^m (RT \ln(p_0/p))^m \right]$$

Where:

- W = volume of the micropores in the adsorbent that is filled with sorbate
- W_0 = total volume of the micropores
- k = characteristic parameter of the adsorbent related to the pore structure
- β = scaling factor and characteristic of the adsorbent
- R = universal gas constant
- T = temperature
- p_0 = saturation vapor pressure of the sorbate
- p = pressure
- m = small integer, characteristic of the adsorbent
- β = characteristic free energy of adsorption

From examination of these equations, it is evident that several of the terms are characteristics of the adsorbent. These characteristics are statistical in nature and some can be determined by experimentation. In fact, it is shown in references that the D-R equation is actually a special form of the D-A equation². The D-A equation assumes that the pore sizes in the adsorbent follow a Gaussian distribution while the D-R equation assumes they follow a Weibull distribution.

Generative and Non-generative Adsorption

The earliest adsorption refrigeration systems used “non-regenerative” systems³, where heat from a hot sorption bed was discarded from the system without being utilized for heating the cold bed. (See Figure 3 below).

Figure 3. Two-Compressor, Non-Regenerative Adsorption Refrigeration System

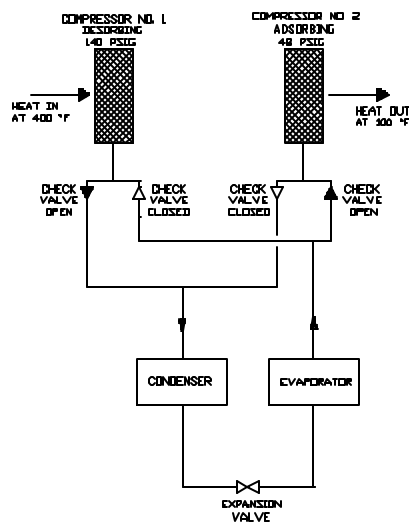

In the above figure, two adsorption compressors are operated out of phase. Heat is added to one compressor while it desorbs the refrigerant and heat is removed from the other compressor while it adsorbs refrigerant. This allows for a continuous flow of refrigerant through the system. The system is inherently simple and it has few moving parts. Its primary disadvantage is its efficiency. The heat added to a compressor to desorb the refrigerant is removed and “wasted” after desorption is completed. As the process repeats, heat is added and then removed and exhausted to the surroundings.

In an attempt to improve the efficiency of this non-regenerative design, Tchernev¹ developed a regenerative technique that transfers heat between the two compressors (Figure 4). The system utilizes an auxiliary fluid that extracts heat from a hot bed that just completed its refrigerant desorption process, and transfer that heat to a cold bed that is ready to start its warming phase. The use of a regenerative heating concept reduces the net heat input to the sorption beds and increase the systems overall efficiency. A more descriptive definition of the regenerative heating operations is provided below and in the Adsorption Compression Experimental System Description section of this paper.

Figure 4. Regenerative Fluid Circuit for a Two -Compressor Adsorption Refrigerator

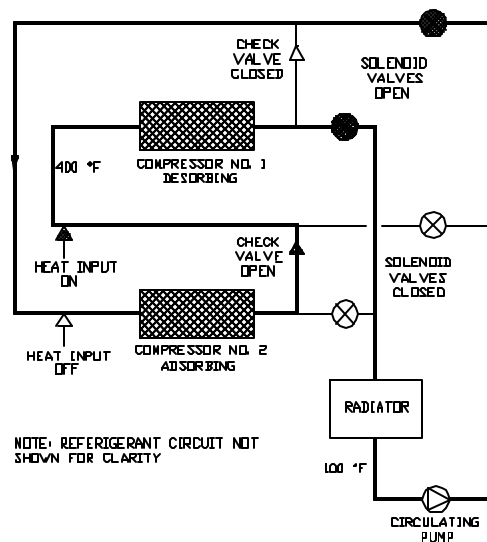

This design makes use of a regenerative fluid, independent of the refrigerant circuit, such as water or glycol. Heat must still be added to overcome heat transfer inefficiencies and a small circulating pump is required for the regenerative fluid. Since the amount of heat that must be added is greatly reduced, the efficiency of this design is significantly higher than the non-regenerative system.

The CSULB adsorption refrigeration unit was specifically designed to implement this regenerative technique. For even higher efficiencies, the two-compressor element design was replaced by four compressor elements.

Application in Automotive Air Conditioning Systems

The air conditioning (A/C) systems in automobiles are comprised of the same basic components as all vapor compressor refrigeration systems and include a compressor, condenser, expansion device, and an evaporator. All newer vehicles use R-134A as refrigerants. R-134A is a hydro chlorofluorocarbon, less harmful to the environment than the previously used R-12.

The parameters affecting the performance of automobile A/C systems are highly transient. The system performance is directly related the operating mode of the vehicle. If the vehicle is idling, the compressor speed and amount of airflow to the condenser will be significantly less than when the vehicle is accelerating or cruising. Table 1 provides system parameter data for these two operating conditions¹.

The schematic of the vapor compression system, instrumentation, and electrical requirements are shown in Figures 5 ad 6. Figure 7 shows the experimental vapor compression system with mechanical compressor (The Cold End). The system consists of a standard ammonia R-717 refrigeration circuit and a chilled water circuit. The ammonia circuit and chilled water circuit are coupled via a heat exchanger. Heat is transferred from the surrounding air to the chilled water circuit via an air-handling unit. The chilled water circuit transfers heat to the ammonia circuit and rejects it at the air-cooled condenser. The chilled water circuit also contains a 15 KW electric load heater that can be used to provide a heat input to the system. This is useful during performance testing because the heat input from the load heater is essentially constant and easily measured for each run whereas the heat input from the air handling unit varies with the ambient conditions and is more difficult to measure. A 7-GPM pump is used to circulate water in this circuit.

Work is input into the ammonia system via a two cylinder reciprocating mechanical compressor. Throttling of the refrigerant is accomplished by one of three methods. Depending on the position of the isolation valves VCE 17, VCE 18, or VCE 19, the refrigerant can be throttled using a thermostatic expansion valve, hand (or automatic) expansion valve, or high pressure float valve. Each type of valve will have a slightly different effect on the refrigerant expansion. This effect and a further description of each valve will be examined later.

Table 1. Typical Operating Parameters of an Automotive A/C System

Parameter	Idle	Cruising
Outside Air Temp (°F)	120	100
Relative Humidity (%)	22.4	40
Evap. Air Flow Rate (CFM)	250	250
Evap. Disc. Air Temp (°F)	70	50
Cond. Air Flow Rate (CFM)	600	2000
Cond. Disc. Air Temp (°F)	154	118
Refrig. Mass Flow Rate (lbm/min)	4.93	6.93
Comp. Suct. Press (psia)	67	44
Comp. Suct. Temp (°F)	62	39
Comp. Dish. Press (psia)	323	250
Comp Dish. Temp (°F)	201	195
Comp. Horsepower	2.54	4.35
Cond. Out Press (psia)	307	238
Cond. Out Temp. (°F)	158	123
Cond. Cooling Capacity (Btu/min)	329	569
Evap. In Press (psia)	82	53
Evap. In Temp. (°F)	67	44
Evap. Out Press (psia)	74	48
Evap. Out Temp. (°F)	62	39
Evap. Latent Load (Btu/min)	20	175
Evap. Sensible Load (Btu/min)	199	207
Evap. Cooling Capacity	219	382
Comp. Power (Btu/min)	107	184
Comp. Power Loss (Btu/min)	3.2	5.5
A/C Blower Power (Btu/min)	16	16
System Power (Btu/min)	127	205
Cycle COP	2.04	2.07
System COP	1.73	1.86

Evaporator Inlet Conditions

Idle - 120°F x 22.4%R.H.

Cruising - 100°F x 40% R.H.

Ambient Conditions - 100°F x 40% R.H.

Refrigerant - R134a

Figure 5. Schematic of the vapor compression system and instrumentation

Figure 6. Sorption Lab Electrical Wiring Diagram

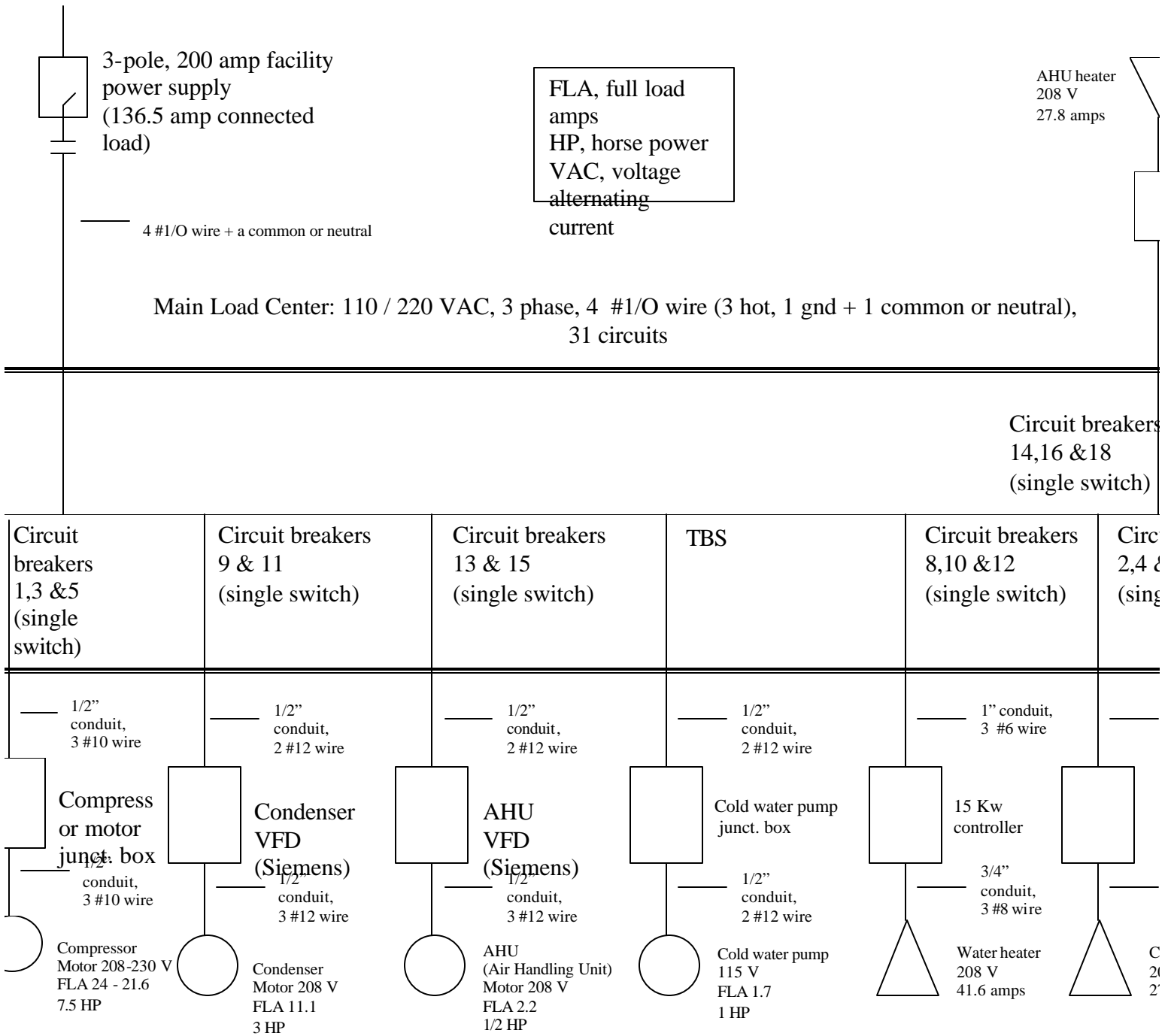
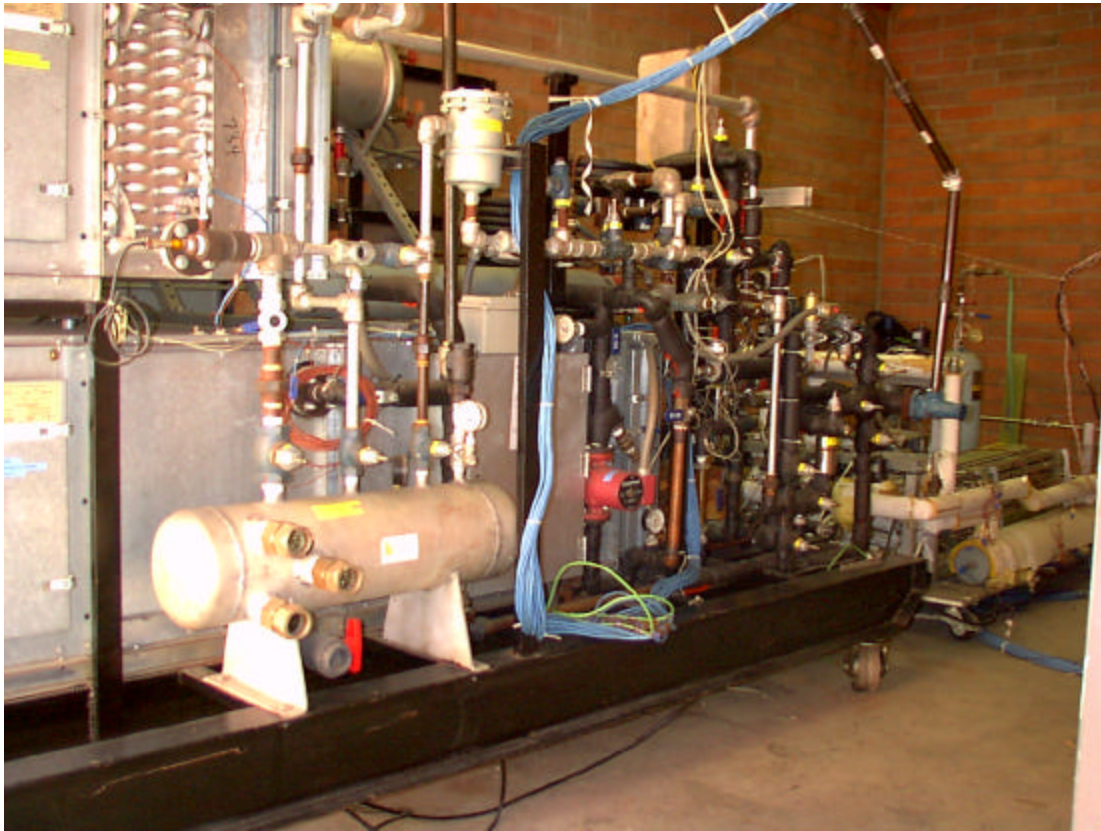

Figure 7. Vapor Compression System with Mechanical Compression



System Components

The system schematic shows various components required for the operation of the entire system. The obvious primary components of this or any refrigeration system include the compressor, condenser, expansion valve, and evaporator. These are the necessary components required to change the “thermodynamic properties” of the refrigerant in order to produce a refrigerating effect. There are, however, several other secondary components necessary for the complete system to function. This section of this report will briefly describe each of these primary and secondary components and their function.

Mechanical Compressor – The compressor in this system is a two-cylinder reciprocating type model A-23 manufactured by Howe Inc. of Chicago Illinois. Its displacement rating is 42.4 cu. in. per revolution, which provides 11.53 CFM at 470 RPM. It is belt driven by a 7.5 HP marathon electric motor. The compressor and motor were mounted on a common skid and as a complete assembly. The compressor’s purpose is to move the heat-laden vapor refrigerant coming from the evaporator (or water chiller in our case) through the rest of the circuit. This is the location where work is input into the system.

Air Cooled Condenser – The condenser is the point in the system where heat is rejected from the refrigeration cycle. The condenser in this system is a air cooled finned forced convection type consisting of a finned coil attached to a fan.

Expansion Valve(s) – The expansion valve in a vapor compression system controls the flow of refrigerant through the system. This valve will throttle the high-pressure refrigerant coming from the condenser as it enters the evaporator. This system has three different types of expansion valves arranged in parallel. They are arranged in a manner that allows the operator to control which type is used by closing isolation valves on the other two. Only one of the three expansion valves is used at a one time.

Hand Type - The hand type expansion valve is a manual means of controlling the refrigerant expansion. The valve is set by hand as its name implies. This type of valve will throttle the liquid refrigerant down to a constant pressure entering the evaporator while the compressor is running.

Float Type – The float valve on this system is an inverted bucket type. It has an internal bucket that acts as a float. When the liquid is introduced, the bucket will drop and allow the valve to open and liquid to pass. If gas is introduced the bucket will rise and close the valve. The valve will remain closed until liquid builds up in the float chamber. When operating this system using the float valve, the receiver tank should be bypassed.

Thermostatic Type – The thermostatic type valve is the most effective valve for controlling the refrigerant flow because its position will vary according to the evaporator load. It has a sensing bulb that is attached downstream of the evaporator. This bulb contains a fluid and is connected to a diaphragm in the valve. The fluid pressure will rise or fall based upon the evaporator temperature and exerts a pressure on the diaphragm. The diaphragm is connected to a needle in the valve that will throttle the refrigerant accordingly.

Evaporator (Water Chiller) – The evaporator on this system is a water chiller. It transfers heat from the chilled water circuit to the refrigeration circuit. The entire evaporator is covered with a spray on foam insulation so little information is known about it.

Suction/liquid Heat Exchanger – The system contains a suction/liquid heat exchanger that transfers heat from the lower temperature gas leaving the water chiller to the higher temperature liquid entering the expansion valve. Transferring heat between these two locations is common in refrigeration systems for two primary reasons. The first reason is to provide liquid refrigerant to the expansion valve at a slightly lower enthalpy. This will permit more heat transfer to the refrigerant in the evaporator and results in a slightly higher coefficient of performance. The second reason is to protect the compressor from liquid entering on the suction port. Any remaining liquid is usually vaporized because of this heat transfer.

Hot Gas Bypass Heat Exchanger – The hot gas bypass heat exchanger is a device used to provide an artificial load on the compressor during low actual load conditions. This is another common device in many refrigeration systems. In a low load condition, such as

the case when very little heat is being input into the refrigerant at the evaporator, the compressor would normally shutoff. Repeated stopping and starting of the compressor is not desired because it causes excessive wear. The hot gas bypass heat exchanger will bypass some of the hot compressed gas from the compressor discharge to the suction side, thus providing an artificial load on the compressor. This will cause the compressor to continue running.

Receiver Tank – The receiver tank is basically a storage tank for liquid refrigerant. The refrigerant can be pumped out of system and stored in the receiver when servicing portions of the system. The receiver also makes the quantity of refrigerant in a system less critical by providing some reserve liquid refrigerant.

Filter Dyer – This system has a filter dryer installed in the liquid line leaving the condenser. It is common practice to install such a device at this point to keep moisture, dirt, and debris from entering the downstream expansion valve. Any moisture at this point in the cycle could potentially freeze in the expansion valve.

Instrumentation

The existing instrumentation on the system consists of thermocouples and temperature gages for temperature measurement, transducers and pressure gages for pressure measurement, and a turbine flow meter for refrigerant flow measurement.

Thermocouples – The thermocouples used on this system are Type T (copper-constantan) normally used for reading temperatures from (-328 F to +752 F). These thermocouples, as well as all other types, consist of a bimetallic junction that produces a voltage output is related to the temperature of the junction. It should be noted that the thermocouples used on this system are not located directly in the flow stream of the refrigerant. They are mounted, using hose clamps, to the exterior of the pipes that carry the refrigerant. This is compensated for by conducting longer experimental run times to allow for a steady state temperature condition to result and therefore provide more accurate data.

Flowmeter – A turbine flowmeter, used to measure refrigerant flow, is located downstream of the condensing unit. The meter is an FTO model manufactured by Flow Technology Inc. formerly EG&G Flow Technology. This meter has a modulated carrier (RF) pickoff that senses the turbine rotation and provides a frequency output. Two additional signal conditioning components are also installed on the system that convert the frequency output to a scaled voltage that can be read by a data acquisition system.

Pressure Transducers – The pressure transducers used are a thin film “strain gage” type Model PX603 manufactured by Omega Engineering. The transducer will accept any excitation voltage from 10 to 30 VDC and will provide a signal voltage from 1 to 5 VDC that is linearly proportional to the rated pressure. 0 to 300 PSIG and 0 to 200PSIG are the rated pressure for all of the units used here.

Data Acquisition

The data acquisition system is used for reading signals from the system instrumentation, converting them into engineering units, and storing them electronically for later analysis. This is accomplished using both hardware and software. A schematic of the data system is shown in Figure 8. Figure 9 shows the configured and installed system.

Figure 8. Data Acquisition System

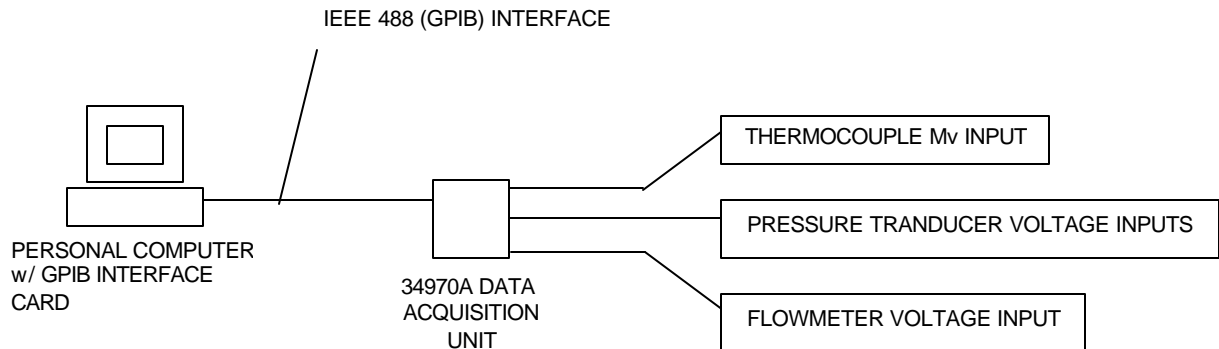

Hardware – The hardware used consists of an Agilent 34970A Data Acquisition/Switch unit and a personal computer. The 34970A unit is essentially a multiplexing voltmeter that reads the voltage output from the various sensors (thermocouples, pressure transducers, and flow meter). The unit has slots in the rear that accept various types of module cards depending on the type of inputs it is reading. The 20 channel multiplexer cards have been selected for our application because they accept voltage inputs and have a built in cold junction reference for reducing the thermocouple inputs and converting them into temperature. This unit can be connected to the personal computer through the standard RS-232 port or via a IEEE-488 (GPIB) interface. The personal computer used is a 75 MHz Pentium. A National Instruments PCI-GPIB Board is used for communicating with the 34970A.

Software - LabView software is utilized to initialize and command the 34970A unit. The software also automates the data collection, reduces voltages to engineering units, and stores the reduced data for later analysis. LabView is a graphical programming language written by National Instruments. It allows the user to easily create a visual “front panel” interface along with an associated programming block diagram. It has all of the same language capabilities of a standard programming language such as FORTRAN or BASIC.

Figure 9. Data Acquisition and Control System



Figure 10: Mechanical Compression Test Cold-end Run Temperatures

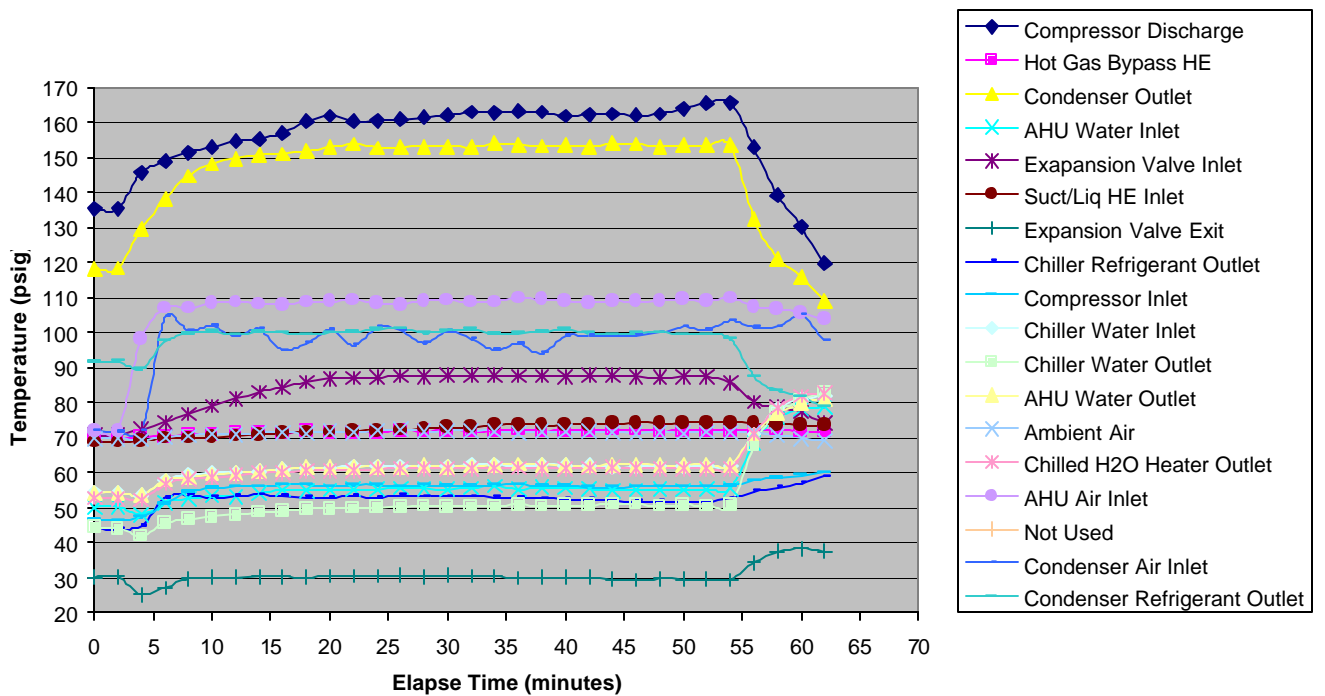

Results

After the system was checked to assure proper safety measures, it was tested for possible leaks and was operated per the procedure “CSULB Ammonia Air Conditioner Activation Detailed Operating Procedure”. The data acquisition was setup according to “Data Acquisition and Performance Analysis of a Vapor Compression Air Conditioning System”. These documents are available and can be accessed by logging to the project website.

The results of sample test run along with thermodynamic properties of various data points are shown in Table 2. Each run lasted approximately one hour. After 10 minutes steady conditions were reached until system was shutdown after 55 minutes of operation (See Figure 10 for a typical trace)

Table 2. Test Data for a Sample Run

Point	Description	T (°F)	P (psig)	H (Btu/lbm)	S (Btu/lbm.R)	Sensor
1'	Evaporator Outlet	45	35	645	1.40	TC8
1	Compressor Inlet	49	34	635	1.33	TC9 / PT1
2	Compressor Outlet	168	180	728	1.34	TC1 / PT4
2'	Condenser Inlet	145.8		674	1.30	TC3
3	Condenser Outlet	93.3	181.6	149	0.306	TC18 / PT2
3'	Expansion Valve Inlet	81.9	179.1	143	0.345	TC5 / PT3
4	Expansion Valve Outlet	28.4	40	143		TC7
4'	Evaporator Inlet					
5	Chilled Water Inlet (evaporator)	59	14	27		TC10.
6	Chilled Water Outlet (evaporator)	49	3.3	17		TC11
7	Cooling Water Inlet (compressor)	67.6		36		
8	Cooling Water Outlet (compressor)	70.4		38		
9	Condenser Cooling Air Inlet	99.9				TC17
	Ambient	69.5	14.7			

Coefficient of Performance

The ratio of the evaporator useful refrigeration effect and the enthalpy increase of the refrigerant due to the compressor determine the thermodynamic COP.

Using the enthalpy change across the evaporator, the refrigeration effect is

$$q_r = h_1' - h_4 = 645.72 - 142.57 = 503.15 \text{ BTU/lb (approximately 3 tons of refrigeration)}$$

The mechanical work input was provided by a 3.87 HP (164.15 Btu/hr) compressor. Therefore:

$$\text{COP} = q_r/W = 565.32/164.15 = 3.44$$

The overall COP is defined as the refrigeration systems performance based on the ultimate energy rate delivered from the electric motor and considers all losses generated between the motor and the actual energy rate that the refrigerant receives. Including all losses, the coefficient of performance we estimated as 2.00.

Adsorption Compression A/C System

The sorption refrigeration unit obtained from Aerojet is a four-bed activated carbon (Kansi carbon) and ammonia system capable of producing approximately one ton of refrigeration. The unit is comprised of an ammonia refrigerant circuit and a 15% ethylene glycol and water regenerative fluid circuit. The purpose of the regenerative fluid is to warm and cool the carbon sorbent beds in a cyclical manner thus allowing them to desorb and adsorb the ammonia refrigerant as required. Figure 11 shows a schematic of the entire compressor system. Each compressor element has an inlet and outlet for regenerative fluid flow and a single port for refrigerant flow. Refrigerant will flow into the port when the element is sorbing and out of the same port when the element is desorbing. Check valves are used to control the refrigerant flow to and from each element. A circulating pump located in the regenerative fluid circuit, flows the regenerative fluid through the circuit to each element, an electric resistance heater, and a radiator unit. Flow control is achieved by 21 normally closed solenoid valves.

Compressor Elements

Figures 12 and 13 show cut-away views of a sorbent bed. Each of the four compressor elements of this system is comprised of six sorbent beds. Each bed's refrigerant in/out port is connected in parallel to the other three beds, and four each flow inlet (adsorption) and four each flow outlet (desorption) check valves isolate each bed from the other. A typical sorbent bed is constructed of three concentric carbon layers each located next to an annular passage that carries the heat regenerative fluid. The carbon layers consist of powdered carbon that has been bonded to aluminum foam. An aluminum foam density of 5% to 9% by volume was used to allow significant free area for the passage of ammonia. The aluminum foam improves the heat transfer from the regenerative fluid to the carbon adsorbing material and provides a surface for bonding the sorbent material.

Figure 11. Schematic of the Sorption Compressor System

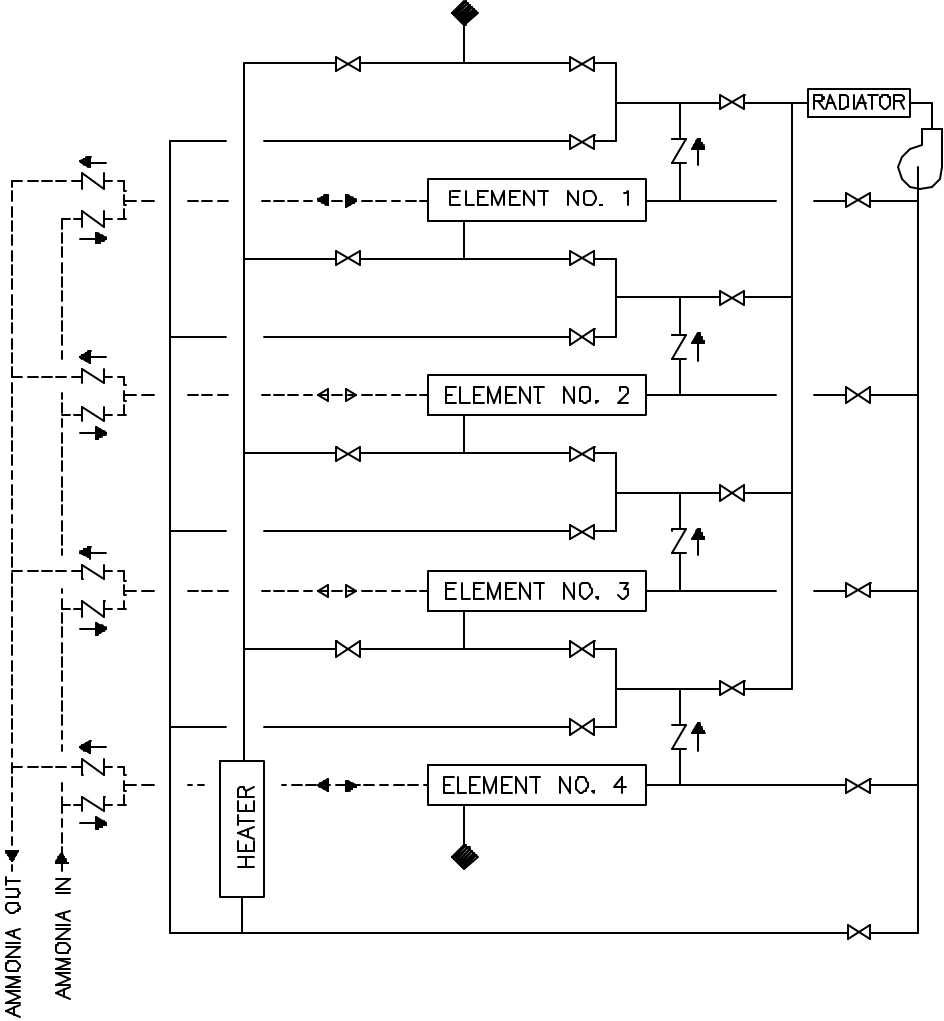

Figure 12. Cut Away View of Compressor Element.

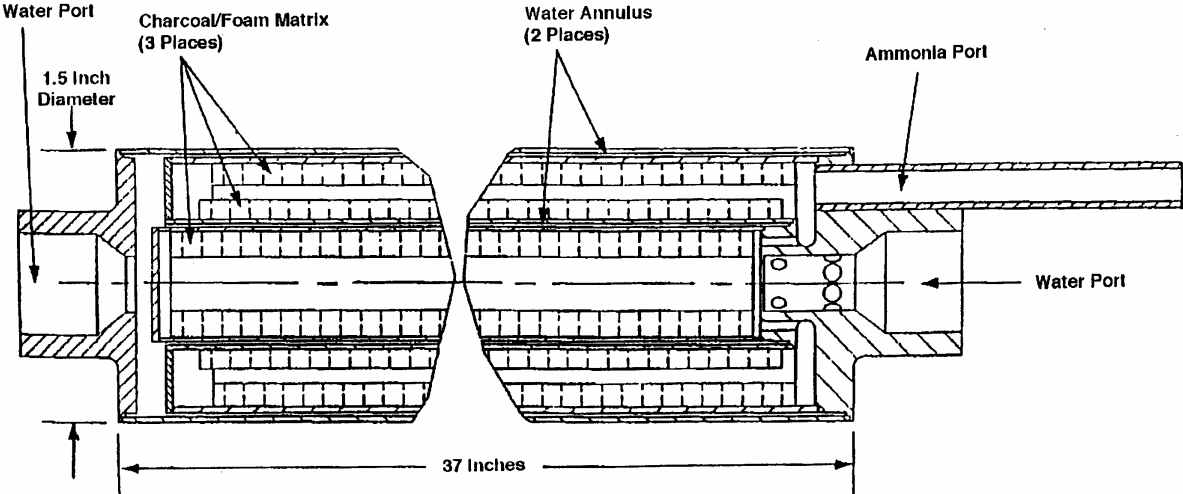

Figure 13. Cross-Section of Compressor Element.

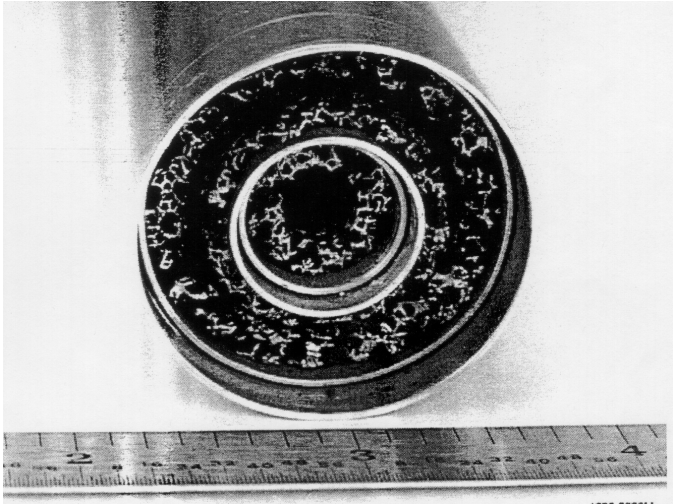
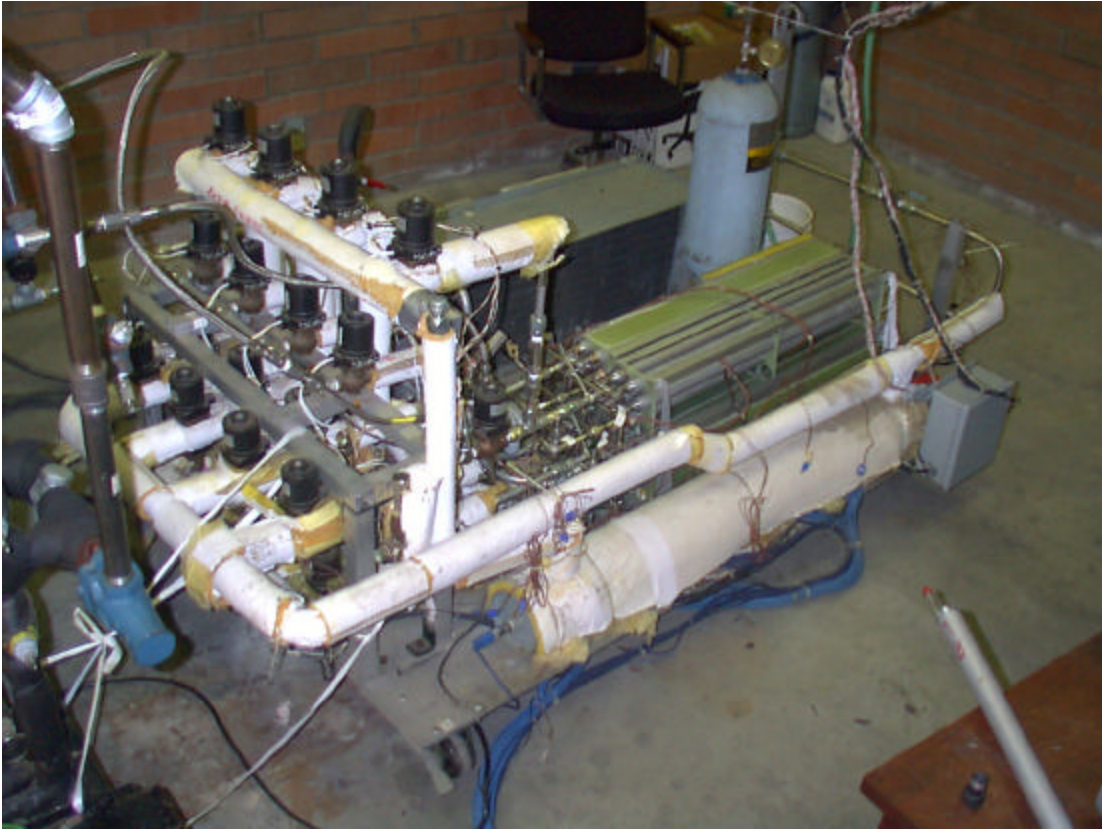

Figure 14 . Adsorption Compressor with Heat Regeneration



Cycling

Operation of the compressor occurs in 4 phases that are continuously repeated while the compressor is running. Each of the four compressor elements are operating in a particular state during each phase of the operation. The operating state of an element is either sorbing, heating in preparation to desorb, desorbing, or cooling in preparation to sorb. Table 3 indicates the state of each element during each phase of the operation. Note that the duration of each phase is approximately 1.5 minutes.

Table 3. Compressor Operating Phases.

	Phase 1	Phase 2	Phase 3	Phase 4
Element No. 1	Sorbing	Heating	Desorbing	Cooling
Element No. 2	Heating	Desorbing	Cooling	Sorbing
Element No. 3	Desorbing	Cooling	Sorbing	Heating
Element No. 4	Cooling	Sorbing	Heating	Desorbing

While the compressor is operating, the regenerative fluid circulating pump operates continuously. The transition from one phase to the next occurs by opening and closing groups of solenoid valves that direct the fluid to the appropriate component in the circuit. An example of the fluid path for Phase 1 would be as follows. Fluid leaves the circulating pump and passes through the radiator where it is cooled to approximately 100 °F. This cool fluid is directed to Element No. 1 causing the beds to cool and adsorb ammonia. The fluid leaving this element is directed to Element No. 4 to begin cooling it since it just finished desorbing in the previous phase. The fluid is then routed to the heater where it is heated to approximately 350 °F. The heated fluid is directed to Element No. 3 and begins desorption of ammonia from its beds. Finally, the fluid is directed to Element No. 2 to begin heating it since it just finished sorbing in the previous phase. The fluid is then returned to the circulating pump to repeat the process. Figures 15a-15d show paths taken by the regenerative fluid during each of the four phases.

Figure 15a. Phase 1 of 4

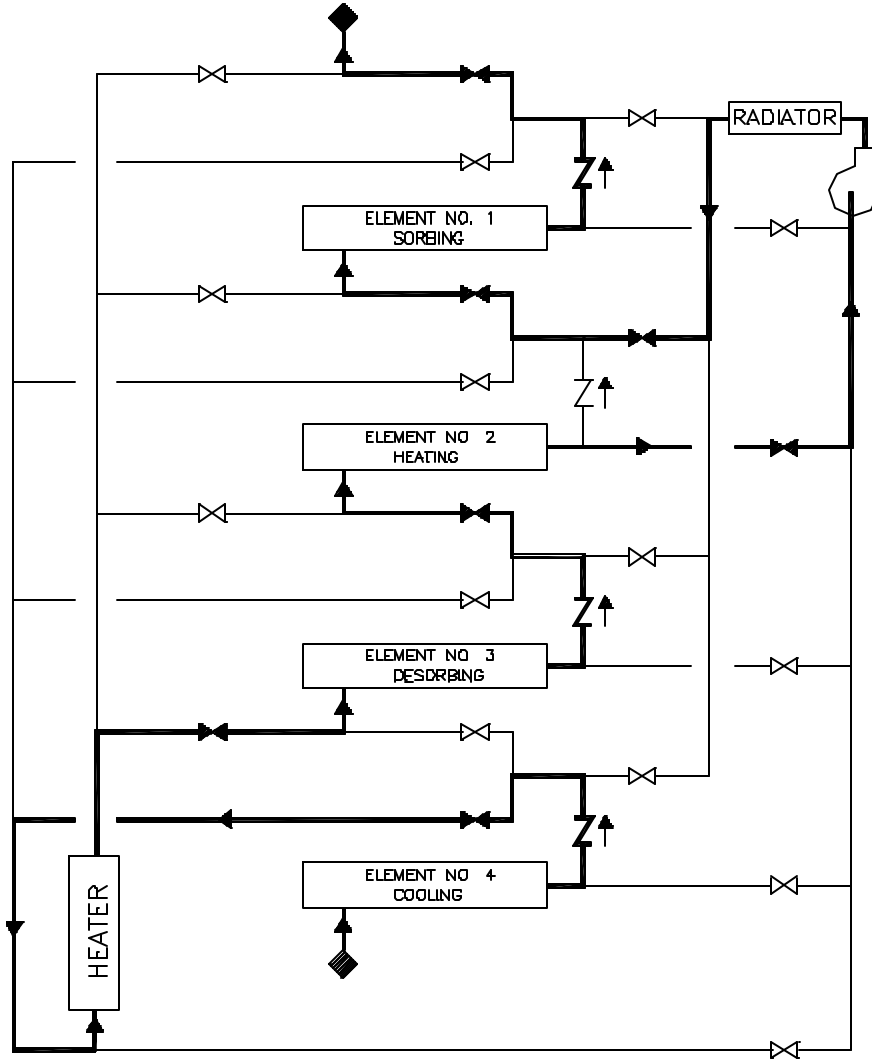

Figure 15b. Phase 2 of 4

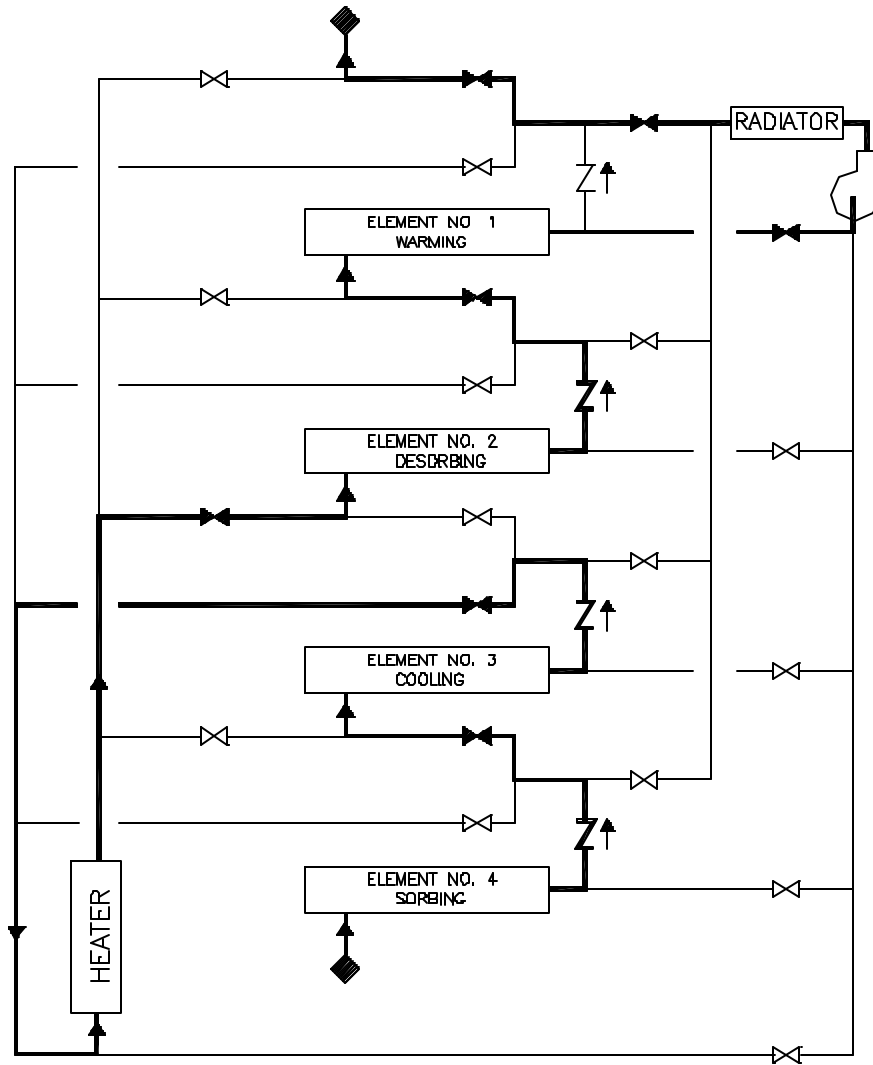

Figure 15c. Phase 3 of 4

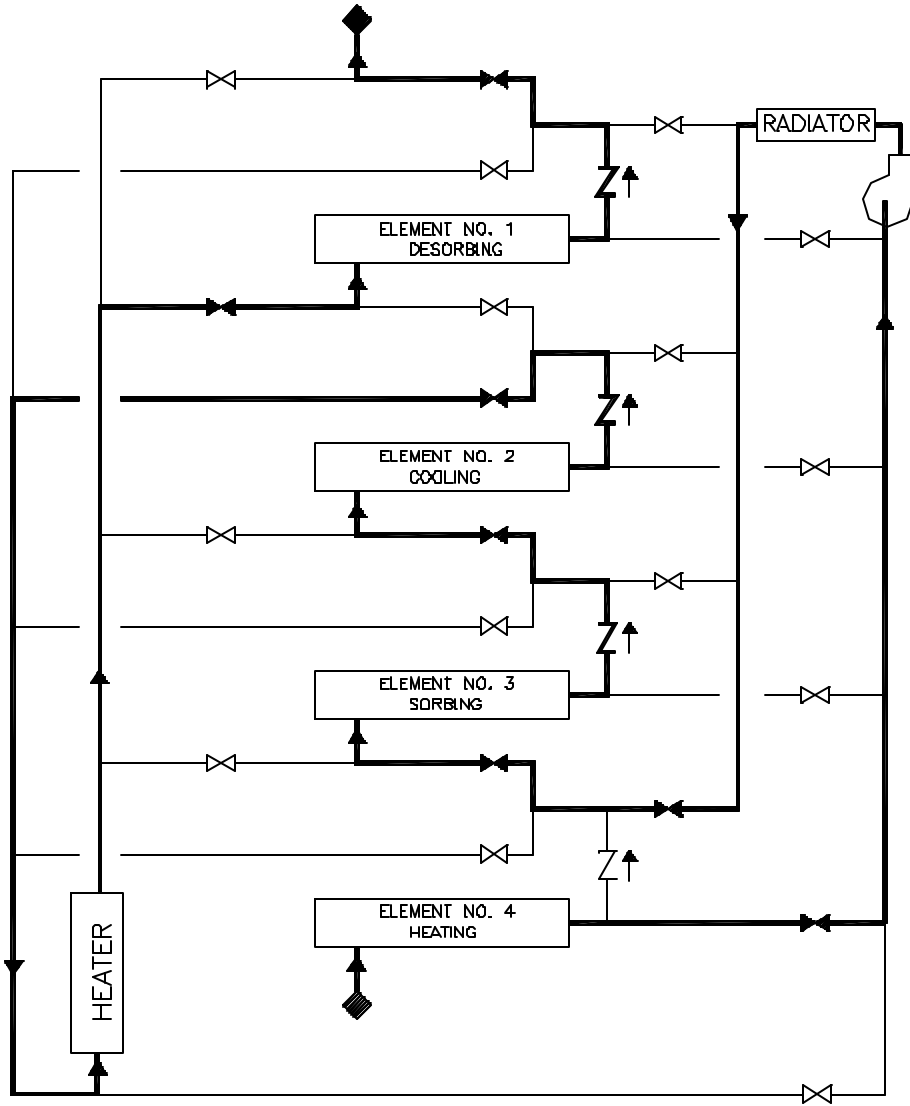
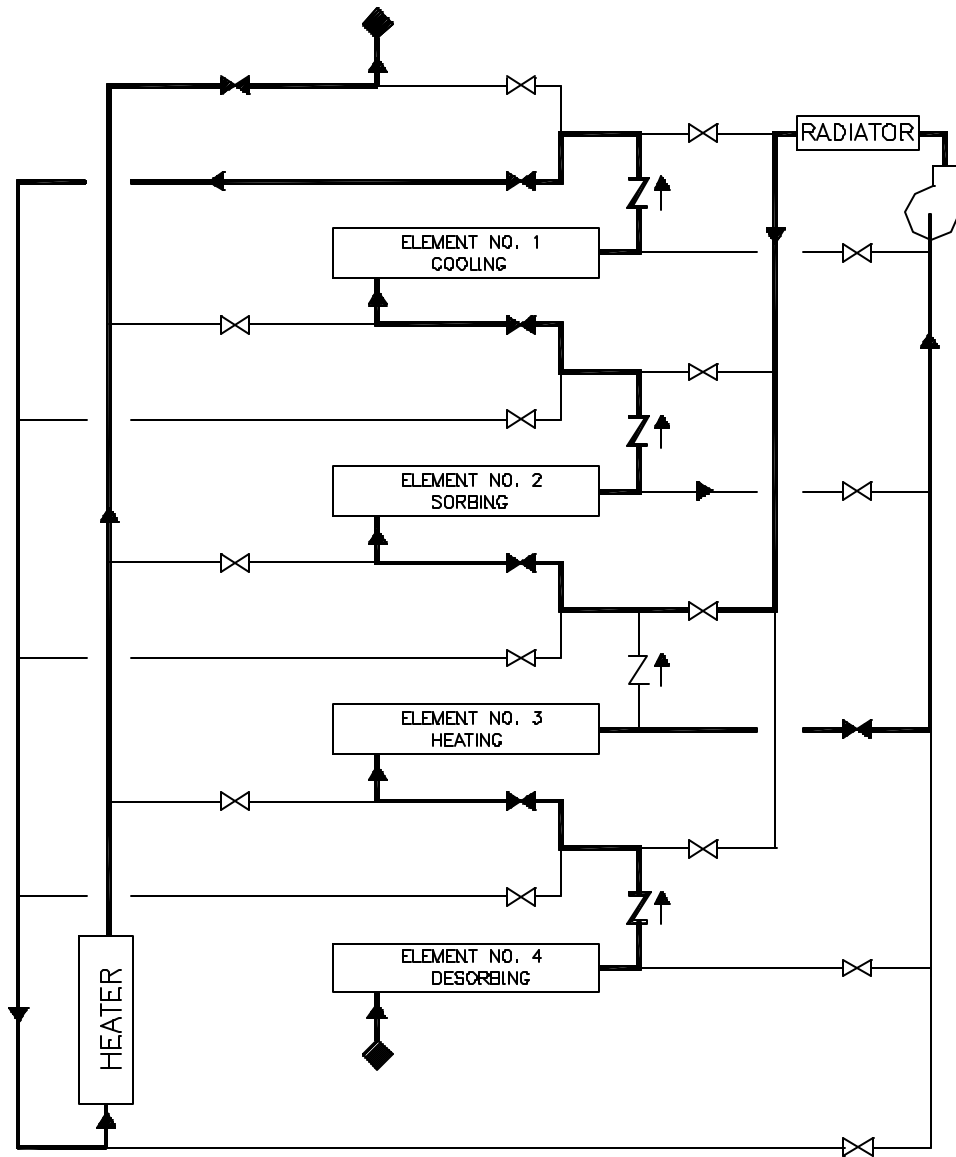

Figure 15d. Phase 4 of 4



Compressor Heating / Cooling Valve Control System

The 21 solenoid valves in the regenerative fluid system are fundamental in controlling the fluid flow and transitioning the unit between phases. The unit was obtained from Aerojet without a control system to operate these valves. A system has been developed using a Pentium personal computer and an Agilent Technologies 34970A Data Acquisition Switch Unit. Seven valves need to be open during each operating phase of the compressor. System is completely cycled in 6 minutes. To accomplish this, the valves were wired to a common power supply by switching module located in the DAQ 34970A unit. Closing the appropriate switches in the module provides power to the appropriate solenoid valves. A computer program was developed to command the switches in the DAQ 34970A unit to open or close based upon the 1.5-minute time interval. The program was developed using National Instruments LabView software. LabView is a graphical programming language with all of the capabilities as conventional line code languages such as FORTRAN or BASIC.

Results

The thermodynamic process data point locations and identifications are shown in Figure 16. Table 4 tabulates all the test data that supports the analysis.

Table 4. Recorded Adsorption Compression Test Data

Point	Description	T (°F)	P (psig)	H (Btu/lb m)	S (Btu/lbm R)	Sensors
1/	Evaporator Outlet	53.0	70.5	629	1.255	TC8
1	Compressor Inlet	54.1	70.03	630	1.26	TC9 / PT1
2	Compressor Outlet/Discharge	64.8	108.1	665	1.27	TC1 / PT4
2/	Condenser Inlet	66.7	106	629	1.22	TC3
3	Condenser Outlet	65	104.8	628	1.22	TC18 / PT2
3/	Expansion Valve Inlet	64.0	103.5	628	1.23	TC5 / PT3
4	Expansion Valve Outlet	50.9	71	625	1.25	TC7
4/	Evaporator Inlet	use ex. valve out				
5	Chilled Water Inlet (evaporator)	80.1	14	48	0.093	TC10.
6	Chilled Water Outlet (evaporator)		4	44	0.085	TC11
7	AHU Water Inlet	76.4				
9	Condenser Cooling Air Inlet	66.0				TC17 (cond. heater "OFF")
	Ambient Conditions	64.0	14.7			TC13

Figure 16. Data Points for Sorption System

Adsorbent bed regenerative heat

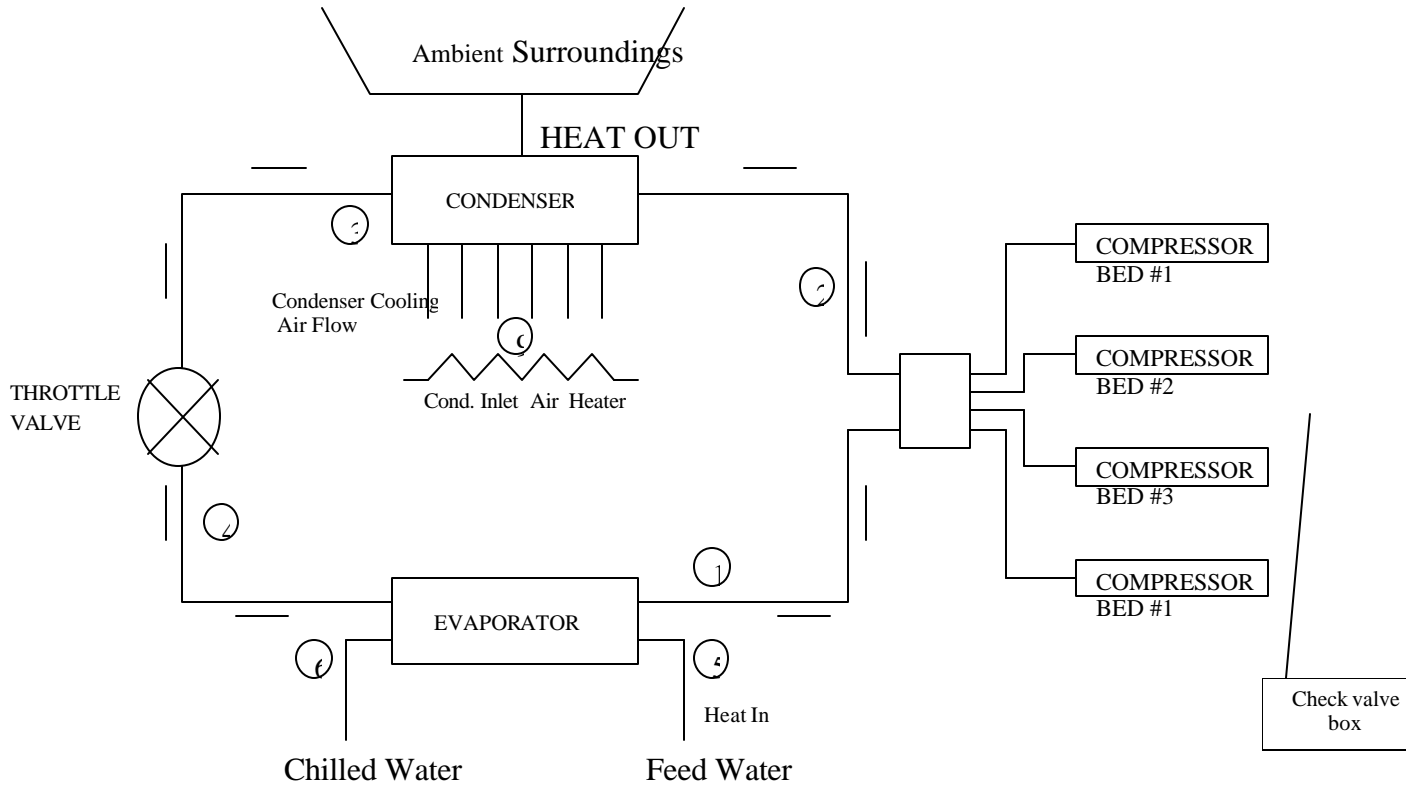
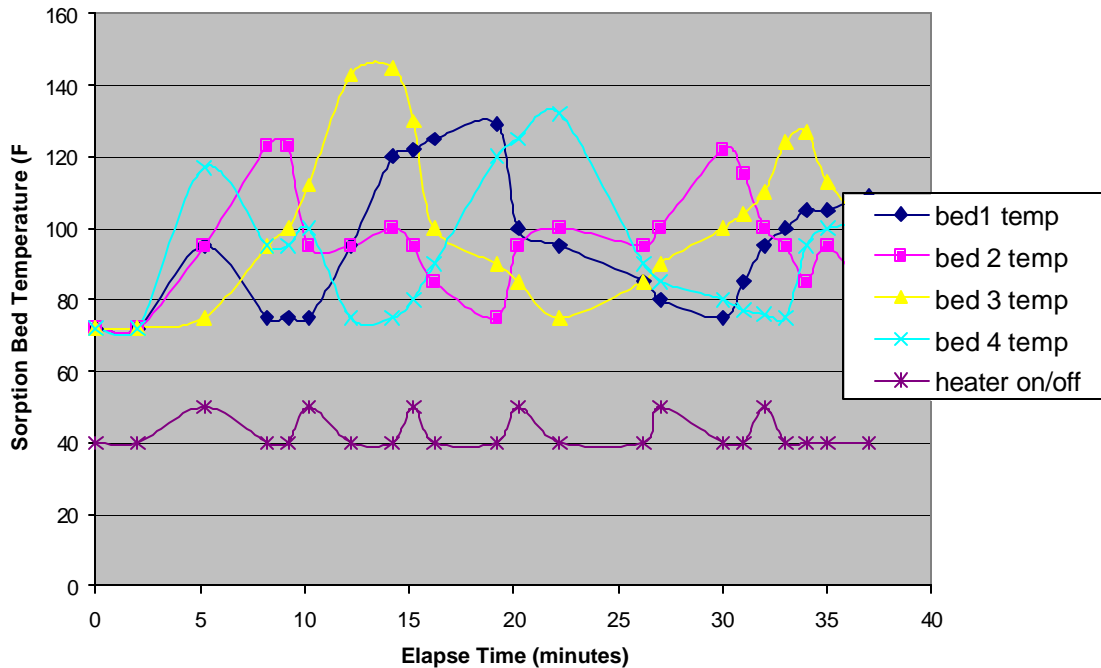

Figure 17. Adsorption Bed Temperatures



Coefficient of Performance (COP)

The ratio of the evaporator useful refrigeration effect and the heater power input determine the overall COP. The refrigeration effect is determined by making an energy balance across the evaporator.

$$Q_r = mc_p \Delta T = mc_p (T_6 - T_5) = 60.14 (0.94)(80.1 - 76.4) = 209.2 \text{ Btu/min}$$

Total refrigeration in T for tons of refrigeration is

$$T = (209.17 \text{ BTU/min}) / (200 \text{ BTU/min/ton}) = 1.04 \text{ tons of refrigeration}$$

The energy input is equal to the adsorption regenerative water heater measured as 307 Btu/min.

Finally, the total/overall COP is estimated as:

$$\text{Total Overall COP} = Q_r / Q_{in} = 209.17 / 307 = 0.68$$

Operational Concept of Sorption A/C System for Automobiles

Figure 18 shows a conceptual design that uses an exhaust line which is tapped off the main exhaust system. The added exhaust line will be attached in parallel to each of the four sorbent beds. Flow to each bed will be controlled by an exhaust flow valve which one each will be dedicated to each bed. When the valve is open, exhaust flow will heat the bed and exit out the exhaust flow check valve and vent to the ambient. At all times a forced air fan will be blowing ambient air across all beds to cool them as close as possible to ambient temperature. Exhaust flow temperatures will overwhelm the ambient air flow for those beds which the exhaust is heating. As the sorbent beds cycle in temperature and therefore pressure, the refrigerant will either flow into them or out from them through a passive check valve system.

The four modes of thermal operations are as follows:

Mode 1: Sorption bed at its coldest temperature.

Refrigerant inlet check valve open for flow, refrigerant outlet check valve closed as the adsorbing bed is at low pressure. This cold adsorbing bed's outlet check valve is closed as high pressure exists on the other side of the check valve from what a hot bed desorbing.

Exhaust inlet solenoid valve closed.

Engine pulley feed blower fan for ambient temperature cooling of the beds (with 80 – 100 F ambient air)

Mode 2: Sorption bed is warming

Exhaust inlet solenoid valve open flowing exhaust around bed housing and then out the exhaust check valve which prevents back flow from other beds. Refrigerant outlet check valve allowing refrigerant flow out when bed temperature and therefore pressure is high enough to overcome downstream pressure created from other beds high temperature out gassing.

Mode 3: Hot sorption bed at its highest temperature

In this mode, refrigerant is at the highest pressure. A refrigerant check-valve allows maximum temperature and pressure refrigerant to exit. Exhaust inlet valve closing at beds maximum temperature limit.

Mode 4: Cooling sorption bed

Continuous ambient airflow cools the hot bed when the exhaust inlet valve is closed. Refrigerant inlet check valve starts to open and outlet check valve is closed as bed is at low pressure.

If four sorption beds are used, this concept is similar to a four cylinder four-cycle engine in that at least one bed has full output while others are in other modes of the overall cycle. In this case, four beds are required to provide a constant refrigerant flow. Refrigerant flow rates can be increased by increasing the number of sorbent beds or by decreasing the heating and cooling times (i.e. by increasing the heat transfer rates). For

automotive systems, the high temperature and high heat rate of exhaust provides the source.

Heat Required Verses Heat Available

Considering a typical passenger car running at a speed of 60 mi/hr and consuming fuel at 1 gal/20 mi. The approximate exhaust outlet heat rate is 25,000 BTU/hr. The approximate heat required into the conventional refrigerant fluid flowing at 5.5 lbm/min is 6,000 BTU/hr.

Consider the heat required to heat the hardware of one or two sorption beds simultaneously is at most twice that required of the refrigerant fluid. Therefore 12,000 BTU/hr could be the heat required of the hardware. At this point the sorbent compressor unit's heat required is less than that produced by the exhaust. A computation was done to show that approximately 1,500 BTUs are required to heat a copper sorbent bed at 10" lg x 5" dia. x 0.125" thick walls from 100F to 250F. The high temperature required of an automotive sorbent compressor may be in the 400F range. The high temperature is required to obtain the proper pressure ratio across the expander.

The required heat will shift the COP of the air-conditioner system to a very low value compared to the 3 to 4 COP of a conventional system. In this application it turns to be acceptable, as the nominal work which goes into a conventional automobile air-conditioner system will be reduced as the mechanical compressor is eliminated and a lower work energy consuming blower fan will be utilized (for cooling the sorbent bed). The compression will be performed in the sorption unit, which utilizes the heat of exhaust or engine/radiator coolant, which is virtually free or "waste heat" anyway.

Figure 18. Sorption Compressor Conceptual Layout for Automotive Applications

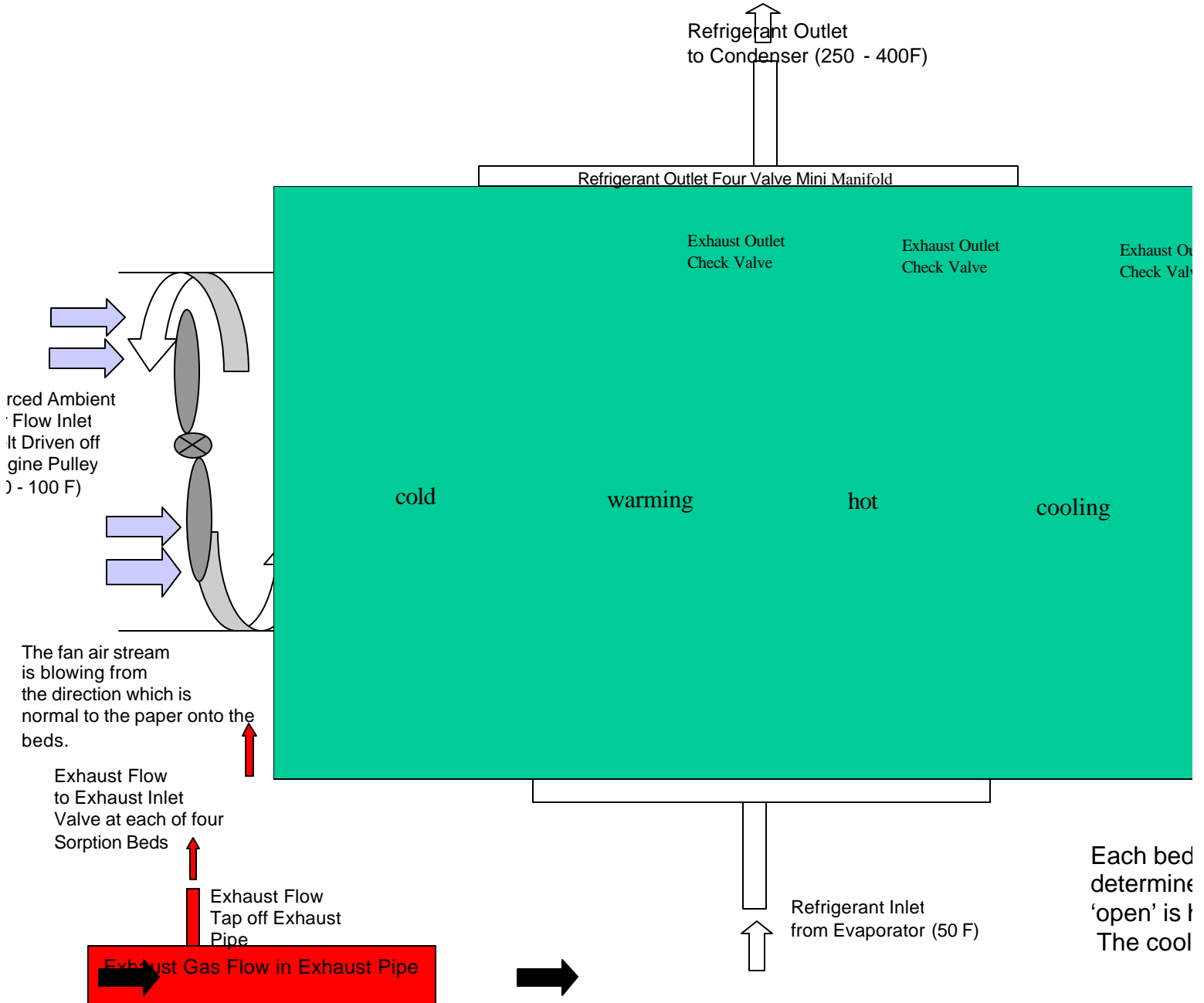

Conclusions and Recommendations

Phase I effort focused mainly on refurbishing the conventional as well as sorption refrigeration units. The system was originally donated to CSULB by MTA after the research budget for this work was significantly curtailed and equipment did not provide sufficient cooling that merited additional budget allocation. We have since revisited the effort and have identified areas that can be improved. Furthermore, the unit provided a useful platform for student research and laboratory experiments.

Because the system had not been used for over five years, much of the valves and sensors were not operational. In addition, there were little documentation, and data acquisition system was missing altogether. We could get very little data from the MTA or the original researchers on the project. For these reasons, refurbishing the equipment was proved to become a momentous task and required much more effort that originally assumed. We also encountered much difficulty in our labs, because the lab location was moved twice and electrical wirings, breaker switches, and piping had to be redone.

Upon completion of this Phase of the project, the unit is fully operational. We have run sample tests and have verified original results reported by the Aerojet and MTA.

Future efforts will include investigating the effects of:

1. System variable such as maximum source temperature and pressure, flow rates, and the refrigerant,
2. Sorbent characteristics such as nature of the sorbent bed, thermal properties, porosity, size of the particles, and binding,
3. Heat transfer modeling of absorbent bed, condenser, evaporator, and other components of the system,
4. Search for other sorbents and refrigerant/absorbent pairs and their applicability for transportation and space refrigeration,
5. System design, prototype fabrication, testing and evaluation.

References

1. S. J. Gregg, L.S.W. Sing, "Adsorption, Surface Area and Porosity", Academic Press, (1982).
2. D.M. Ruthven, "Principles of Adsorption and Adsorption Processes", John Wiley & Sons, (1984).
3. J.A. Jones, V. Christophilos, "High-Efficiency Regenerative Adsorption Heat Pump", ASHRAE Transactions, Vol 99, Part 1, pp.54-60.
4. Kirk-Othmer, Encyclopedia of Chemical Technology, fourth edition- volume 2, John Wiley & Sons
5. National Bureau of Standards Circular No.142, *Tables of Thermodynamic Properties of Ammonia*
6. Keenan and Keyes, *Thermodynamic Properties of Steam*, Wiley 1936.
7. J. Kenneth Salisbury (Editor), Kent's Mechanical Engineers' Handbook, Power Volume, John Wiley & Sons.